

CF07 CLUSTER HOUSING

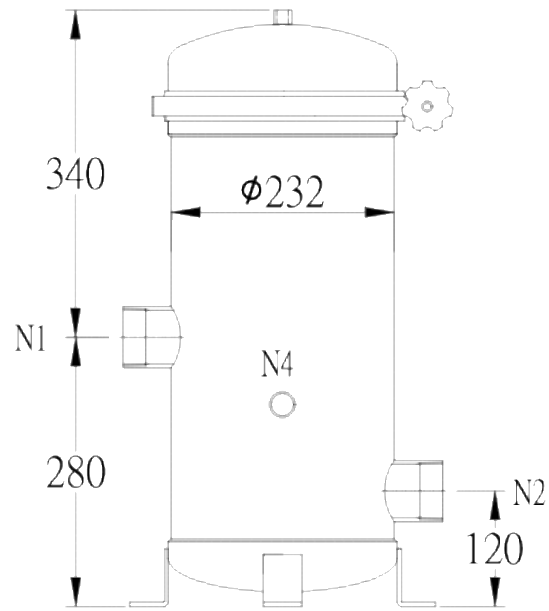

- N1 1 ½" F NPT Inlet
- N2 1 ½" F NPT Outlet
- N3 1/4" F NPT Vent
- N4 3/4" M NPT Drain

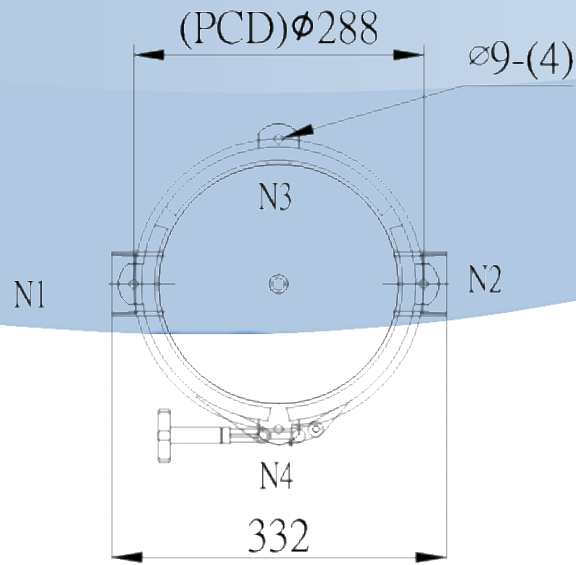
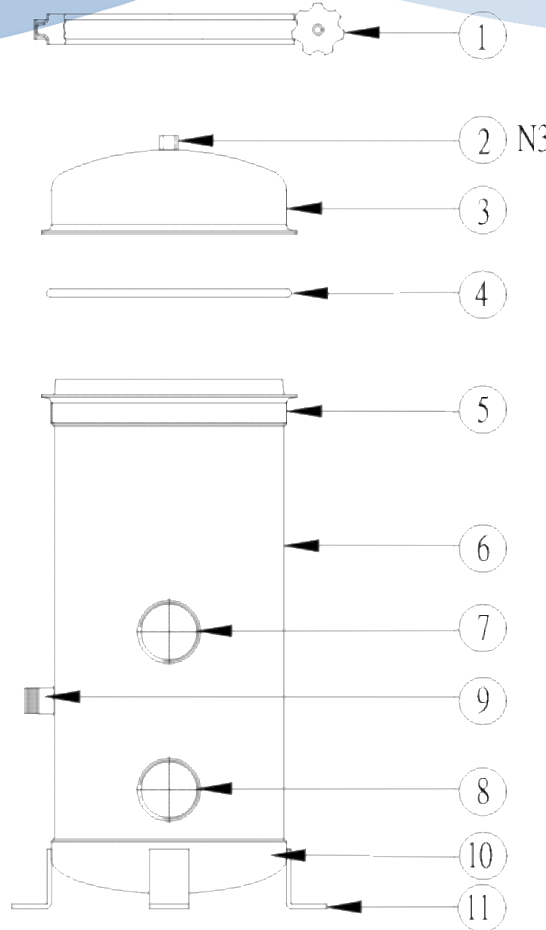

Max working pressure 30 – 150 psi
 Working temperature 1 - 50°C
 Surface 304 or 316
 Material Electrolyze

- | | | |
|----|-------------------------|--------------------|
| 1 | Clamp | 304 or 316 S/Steel |
| 2 | Vent | 304 or 316 S/Steel |
| 3 | Top Cover | 304 or 316 S/Steel |
| 4 | O-Ring | EPDM |
| 5 | Shell Flange | 304 or 316 S/Steel |
| 6 | Shell | 304 or 316 S/Steel |
| 7 | Inlet | 304 or 316 S/Steel |
| 8 | Outlet | 304 or 316 S/Steel |
| 9 | Drain | 304 or 316 S/Steel |
| 10 | Bottom Cover | 304 or 316 S/Steel |
| 11 | Support Leg | 304 or 316 S/Steel |
| 12 | Nut | 304 or 316 S/Steel |
| 13 | Press Plate | 304 or 316 S/Steel |
| 14 | Springs | 304 or 316 S/Steel |
| 15 | Cartridge Posts | 304 or 316 S/Steel |
| 16 | Center Post | 304 or 316 S/Steel |
| 17 | Nut | 304 or 316 S/Steel |
| 18 | Pedestal | 304 or 316 S/Steel |
| 19 | Cartridge Support Plate | 304 or 316 S/Steel |

