

2,000GPD INDUSTRIAL RO
with ROC 2315 Digital Controller
MANUAL



General Information

This manual is to ensure the safe use, performance and longevity of the equipment and is intended for use by properly trained technical personnel. Please read this manual thoroughly before installing the unit. Keep for future reference.

The manufacturer reserves the right to amend or modify without notice the specifications provided in this manual.



WARNING

Installations and electrical connection must only be done by trained technicians and according to local standards.
Touching live parts may result in serious injury.



WARNING

Do not retighten/unscrew hoses while system is pressurised!
The system start up must be carried out by properly trained technicians.



WARNING

The RO system must be installed and maintained in accordance with this manual to ensure your system stays safe.
Poorly maintained RO systems can be hazardous.

Please observe the following

- It is important to ensure that the system is suitable for the raw water to be processed and that the system is suitable for the mineral content of the raw water.
- The system **must** be installed with the relevant pre-treatment to ensure the membrane is not fouled with particulate matter.
- To ensure the system's pre-treatment is adequate, it is necessary to have the raw water analysed for mineral content.
- The installation site must be freely accessible with sufficient space for convenient operation, maintenance and air circulation.
- The system is designed for operation in a frost-free and dry environment. Never outdoors.
- Do not install the system in exposed locations or locations with heavy dust loads.
- The system is designed for installation on a load-bearing floor.
- All systems must be installed with an inlet isolating valve.

NOTE – The performance of the system is dependent on the quality and temperature of the raw water and the following can only be taken as an initial guide. If your supplier has not provided you with an Analysis Report, request one before installing your system. This will provide you with the correct parameters of operation and will recommend the adequate pre-treatment to ensure the membranes do not foul or block prematurely.

Main System Components

Filtration

The unit is fitted with a double 20" x 4.5" housing system comprising of a 5mic sediment filter and a 10mic carbon block.

These filters are designed to protect the pump and membrane only and are not installed as a system pre-treatment. Changing the cartridges regularly will help prevent excessive blockage that could be detrimental to the system.

Pump & Motor

The pump boosts the raw water supplied up to a level that allows good quality water production. Refer to manual included with unit.

Membrane Housings

These housings are pressure vessels that retain the membranes and must only be operated with the end caps or plugs properly installed.

Membrane

TFC membrane material is NOT compatible with any Oxidisation Agents eg. Chlorine and has a very limited life with exposure. It is important that the agent is completely removed prior to entering the system.

Note the layout, positioning and flow direction of the housings and pipework.

Lubricate o-rings sparingly.

The membrane must be inserted into the housing the correct way. The membrane has an outer "V" brine seal at one end and must be located at the "FEED IN" end, where the water enters the housing.

Inlet Actuator

Shuts the system down when the low pressure switch sends out low pressure signal.

Pressure Regulator (Needle Valve)

The main function of this valve is to control the concentrate flow from the membranes to maintain the correct operating pressure of the system and in conjunction with the recycle valve, the overall recovery of the system.

NEVER OPERATE THE SYSTEM WITH A FULLY CLOSED VALVE

Recycle Valve (Needle Valve)

The main function of this valve is to control the portion of the concentrate flow back into the booster pump suction to enable a higher overall recovery of the system and correct system operating pressure.

NEVER OPERATE THE SYSTEM WITH A FULLY CLOSED VALVE *unless the design is based on "No Recycle"*

CAUTION: DO NOT run the system with the valves completely closed off as irrecoverable membrane or system damage could result

Flush Solenoid Valve

Enables a higher volume of water across the membrane surface to extend the time required between chemical cleans or membrane replacement.

Automatic timer action controlled – in that the system can be programmed to flush at initial start, at tank full and also at selected time spans. Flush timer can be varied in the controller programming.

Manual flushing can be selected by controller. – Manual should only be selected for no longer than 90 seconds.

Flow Meter

These meters indicate the Permeate (Product), Concentrate (Waste) and Recycle flow rates.

Pressure Gauges

Used to monitor the operating conditions of the membrane array and facilitate the adjustment of the recycle and pressure regulator and pump control valves.

Low Pressure Switch

Monitors inlet water pressure and is a safety device that, in conjunction with the digital controller shuts down the system in the event of low feed water pressure.

They system requires an inlet pressure of at least 280 kpa (40 psi) and a maximum of 640 kpa (90 psi). Fit a PRV if the pressure exceeds 640 kpa.

The low pressure switch shuts the system down if the inlet pressure drops below 40 psi and will automatically reset.

The range and differential is adjustable on the switch. Please speak to your supplier before adjusting the switch.

Recycle Non Return Valve

Prevents raw water entering the recycle loop.

NOTE – If this non return valve is not sealing correctly, inlet water will run to waste through this valve when the RO unit is operating.

ROC -2315 Digital Controller

Refer to manual included with unit

Installation & Start Up

- Check the condition of the unit after unpacking and check that no electrical components have come loose in the control cabinet during transportation.
- Influent water temperature should be no higher than 30°C
- Electrical supply required will be 10 amp.

Start Up

Ensure that all service connections are secure and all supply parameters comply.

Ensure that the pressure regulator is fully OPEN.

Ensure that the recycle control valve is fully OPEN.

Ensure that the system gate valve is fully OPEN.

Ensure that electric power is available.

Ensure that adequate water supply is available.

Open system isolating valve.

Vent the two cartridge filter housings by depressing the red buttons on top of the filter housing head.

Check that there is sufficient pressure registered on the inlet gauge.

Turn system on and check pump operation.

Once flushing is complete, adjust the pressure regulator valve as required and recycle valve together.

- If the permeate is above the nominated flow rate then it will be necessary to RESTRICT the flow rate from the high pressure pump to reduce the output from the pump. Slowly close off the system isolation valve. (Note: this valve is a gate valve and will not start reducing the flow until near the shut off position.)
- It will be necessary to continually readjust the pressure regulator and recycle valves and the system isolation valve to achieve the desired flow rates. (Note: the flow rate is very dependent on temperature and operating pressure.) Higher temperature will allow a greater flow and mineral passage through the membrane and the system operating pressure should be reduced accordingly. (Note: new membranes may produce in excess of the nominated rate but will compact in time with a reduced flow rate and it may be necessary to periodically adjust the valves.)
- It is advisable to not run the system so as to produce more than the nominated product permeate flow rate as excess flow will only shorten the membrane life and could scale up the membranes.

★ Minimum concentrate flow – 15.2 lpm C + R Typical @ 50% recovery

- **IMPORTANT:** If the system continually starts/stops under the control of the low pressure switch then the system has insufficient feed water pressure or the supply pipe does not have enough flow/capability to satisfy the Low Pressure Switch during the flushing cycle.

Maintenance

Reverse osmosis membranes will have to be replaced on a regular basis. Membrane life is determined by the quality of the feed water and the recovery. Oxidisation agents like chlorine will destroy the structure of the membrane material layer.

The membranes can be fouled with particle matter and microbiological contaminants and can be scaled by precipitating salts.

It is advisable to only operate the plant at the lowest possible pressure to obtain the desired flow production and to ensure that all pre-treatment is operating satisfactory.

- *Dependant on water quality, the membranes should be replaced or chemically cleaned every 6 months or whenever performance diminishes as set out above. Under good conditions they can last over 3 years.*
- *It is important to change the filter cartridges at least every 3-6 months or whenever the pressure drop across the filters increases to an extent that the flow is restricted.*
- *Additional pre-treatment should be serviced in accordance with the manufactures recommendations.*
- *It is recommended to log the operational data of the system on a regular basis and monitor the performance of the system.*

Troubleshooting

PUMP WILL NOT START

- *Check controller – LOW PRESS LIGHT*
 - *Insufficient water pressure*
 - *Check feed supply*
 - *Check pre filtration*
 - *Check inlet valve is open*
 - *Check settings on low pressure switch*
- *Check controller – TANK LIGHT*
 - *Permeate tank full*
 - *If no permeate tank connected, check wiring in control box*
- *Check controller – FLUSH VALVE LIGHT*
 - *Unit flushing*
 - *Wait for flush cycle to complete*

UNIT WILL NOT START

- *Check power supply*
- *Check circuit breaker*
- *Overload tripped*
- *Pump motor high temp*
 - *Allow to cool*

PUMP STARTS BUT WATER OUTLET PRESSURE LOW

- *Pressure regulator valve fully open*
 - *Close valve according to analysis report*
- *Inspect pump*
- *Brine seal bypass*
 - *Remove and reseal*
 - *If damaged, replace*
- *Flush valve is open*
 - *Close valve*

PUMP STARTS BUT TRIPS

- *Motor overload*
 - *Check overload setting*
 - *220V motors require higher setting than nameplate rating 12-13 Amp*

Troubleshooting

PUMP STOPS AND STARTS

- *Check feed pressure*
 - *Check feed pressure when unit is off, flushing and when pump starts*
 - *If pressure drops below 40 psi, check water supply and pre treatment*
 - *If pressure does not drop below 40 psi, check low pressure switch settings*

EXCESSIVE MEMBRANE PRESSURE

- *Pressure regulator valve closed*
 - *Open valve*
- *Membrane(s) fouled*
 - *Replace or clean membranes*

PERMEATE WATER QUALITY POOR

- *Membrane at end of life*
 - *Replace membrane*
- *Brine seal bypass*
 - *Remove and reseal*
 - *If damaged, replace*
- *Brine seal installed incorrectly*
 - *Install correctly – see flow chart page 9*
- *Membrane perforated by chlorine attack*
 - *Replace membrane*

FLOW CHART

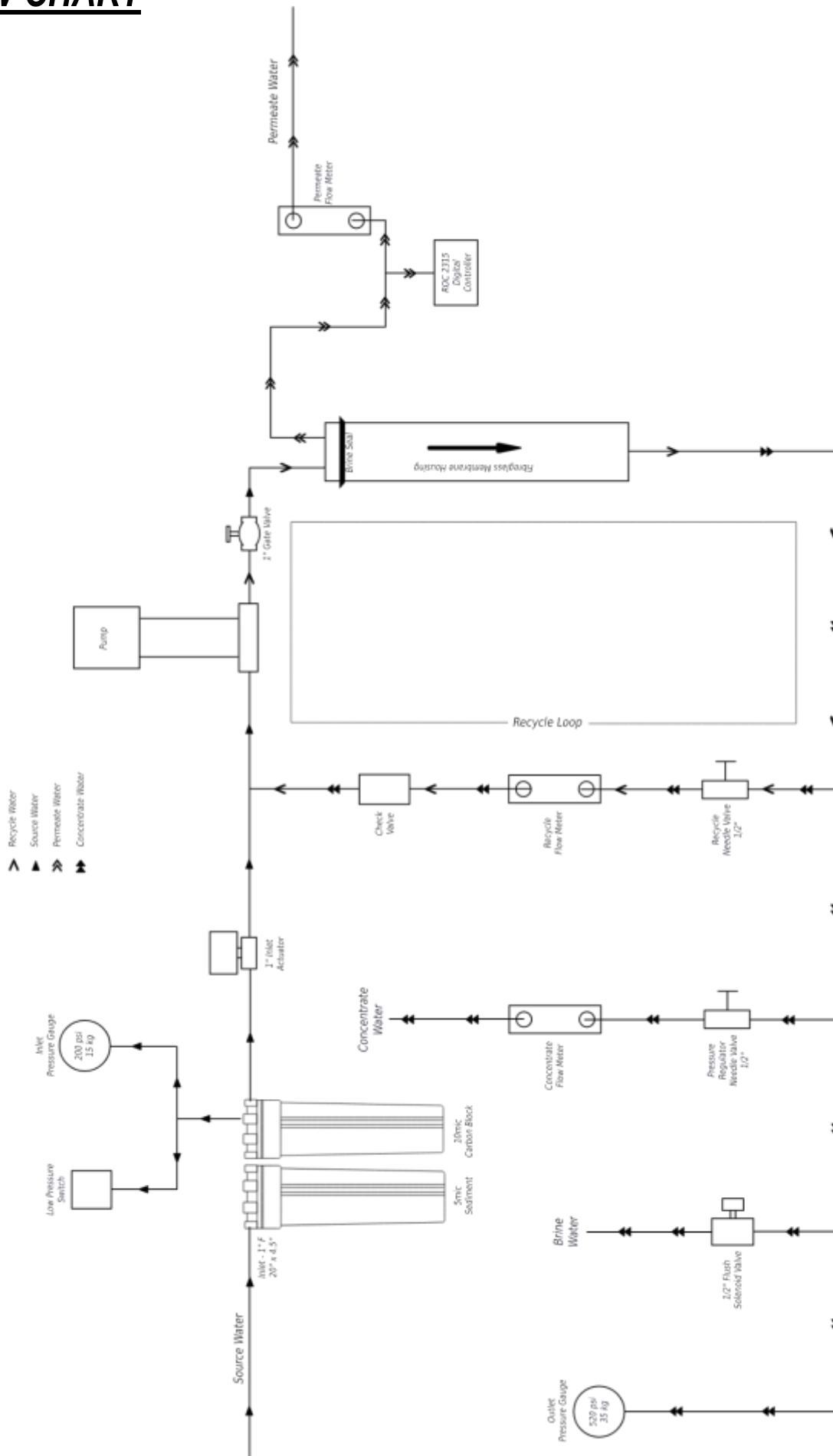

ACTUATOR

UM -1

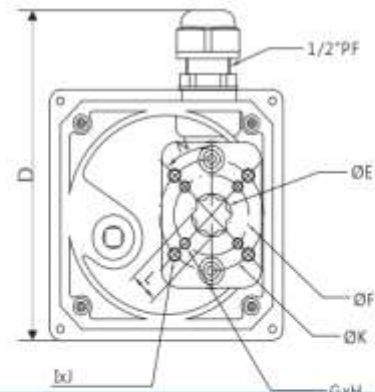
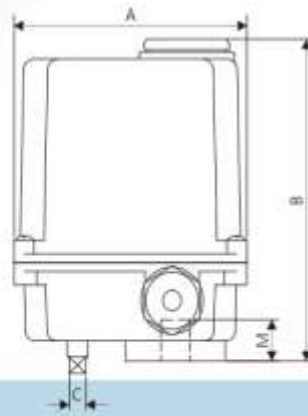
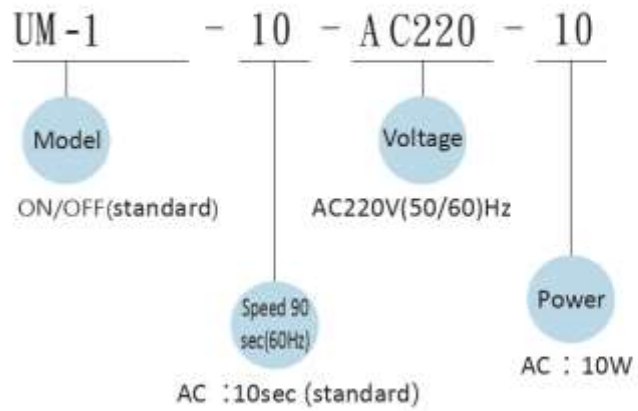

mm

Model	A	B	C	D	E	F	G	H	I	J	K	L Max	M	N	ISO 5211
UM-1	118	145	8	140	19.3	36	M5	4	M6	4	50	14.03	19	45°	F03 / F05

2-PC Screwed End Ball Valve

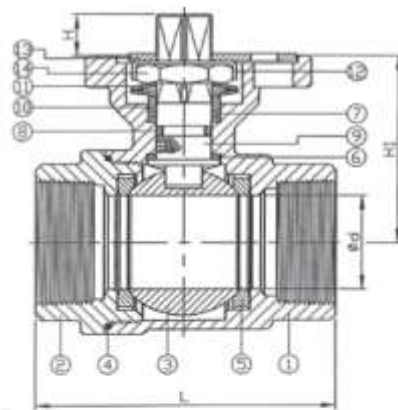

ITEM	PARTS	MATERIAL
1	BODY	ASTM A351-CF8M
2	CAP	
3	BALL	PTFE
4	BODY SEAL	
5	BALL SEAT	RTFE
6	THRUST WASHER	PTFE
7	PACKING	
8	O-RING	VITON
9	STEM	ASTM A276-316
10	GLAND RING	AISI 304
11	BELLEVILLE WASHER	AISI 301
12	LOCK WASHER	
13	STOPPER	
14	STEM NUT	

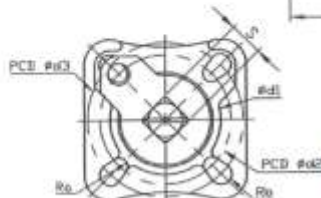

1/2"~1-1/4"

NPS	d	L	H	H1	S	d1	d2	d3	Ra	Rb	Weight (lb)	Torque (in-lb)
1/2"	0.59	2.28	0.31	1.43	0.35	1.22	1.42	1.65	0.11	0.11	0.8	48.7
3/4"	0.79	2.58	0.35	1.54	0.35	1.22	1.42	1.65	0.11	0.11	1	66.4
1"	0.98	3.1	0.43	1.92	0.43	1.4	1.65	1.97	0.11	0.14	1.8	97.4
1-1/4"	1.26	3.54	0.43	2.13	0.43	1.4	1.65	1.97	0.11	0.14	2.7	132.8
1-1/2"	1.5	4.13	0.45	2.59	0.55	2.2	1.97	2.78	0.14	0.18	4.4	177
2"	1.97	4.88	0.45	2.97	0.55	2.2	1.97	2.78	0.14	0.18	6.4	354

unit :in

MEMBRANE HOUSINGS

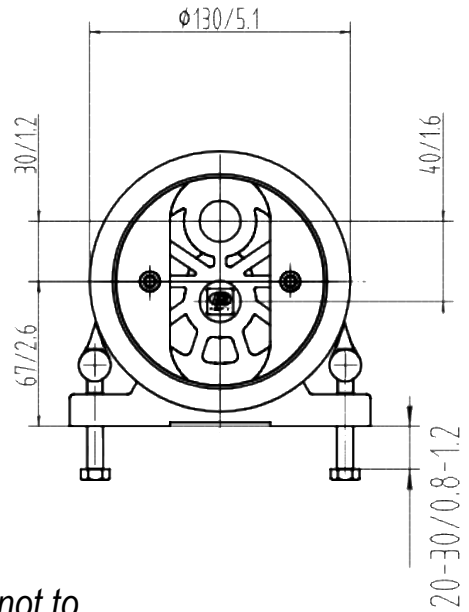
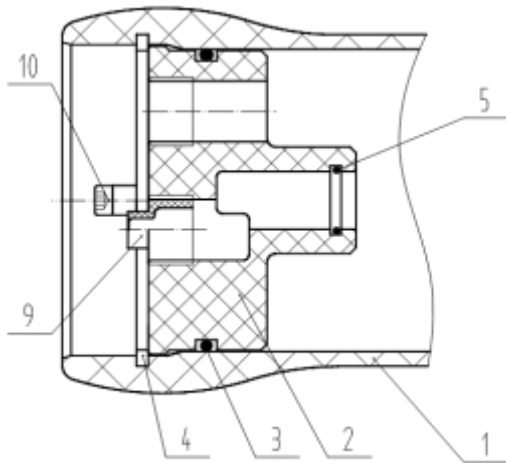

NOTE

➤ Internal permeate pressure not to exceed 125 psi

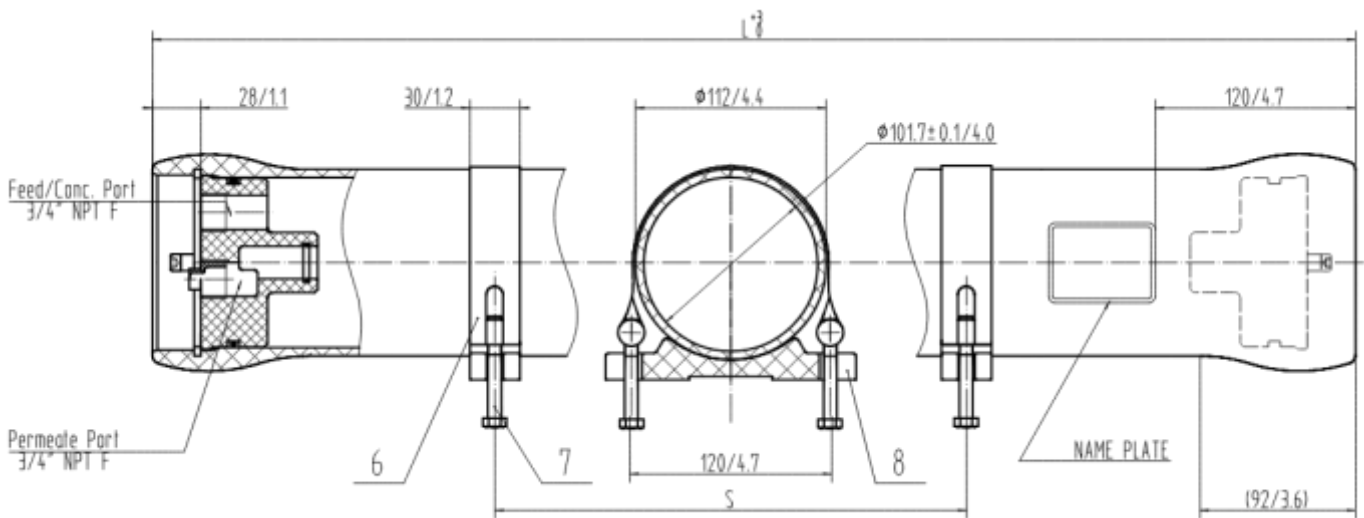

4040 1163 mm (45.8") L 1200 mm (47.2") 8 kg

End plate ports 3/4" F NPT Plug 3/4" M NPT
 Design pressure 300 psi
 Design temperature 66°C
 Min allowable temp -10°C
 Working medium Water PH 3 ~ 11

- | | | |
|----|------------------------|-------------|
| 1 | 4040 Shell | FRP |
| 2 | End plate | ABS |
| 3 | O-Ring | EPDM |
| 4 | Locking Crescent | 304 S/Steel |
| 5 | O-Ring | EPDM |
| 6 | Strap | 304 S/Steel |
| 7 | Strap Screw | 304 S/Steel |
| 8 | Saddle | Rubber |
| 9 | Plug | ABS |
| 10 | Locking Crescent Screw | 304 S/Steel |

General Information

We recommend that only qualified mechanics, experienced in servicing high pressure systems, open, close and service this vessel.

Proper vessel handling and installation are important for safe use and long vessel life. Improper assembly, misuse or corrosion damage can result in mechanical failure, property damage and injury.

These membrane housings are designed for continuous, long-term use as housings for reverse osmosis membrane elements. The filament wound FRP shell is composed of continuous fibreglass impregnated with heated epoxy resin. Cleaning agents must be wiped off and cleaned from the vessel after cleaning.

All decisions as to the suitability for use must include full consideration of the various safety aspects involved. These include, but are not limited to:

- *Process fluid compatibility (eg. chemical and temperature considerations).*
- *External environment factors (eg. corrosive atmosphere, remote or special environments where plastics might be undersirable etc).*
- *Abnormal back pressure which might result in pressurizing permeate port above 125 psi.*
- *Capability of the user to maintain vessel properly.*

Vessel & Accessory Maintenance

Plastic components – Check for any cracks, dents or uneven colour.

Metal components – Check for any corrosion, scratches, dents, cracks or other damage.

Other components – Check for any damage that may affect the stress performance and sealing performance.

Cleaning the vessel

Remove the debris inside the baffle groove with a brush or any other tool.

First 100mm of vessel inside surface should be cleaned with a cloth and soap solution.

Wash away the residue and soap solution inside the vessel with water.

Check for any defects such as scratches, dents or leakage caused by damage in the sealing surface.

Maintenance of other components

Replace any seriously damaged or defective components.

WARNING – Corrupted components may cause serious injury

SPECIFICATIONS:

General Features	Permeate flow rate:	2,400 GPD (9.1 m ³ /day)
	Nominal salt rejection:	99.7%
	Effective membrane area:	85 ft ² (7.9 m ²)

1. The stated product performance is based on data taken after 30 minutes of operation at the following test conditions:

- 2,000 mg/L NaCl solution at 225 psig (1.55 MPa) applied pressure
- 15% recovery
- 77 °F (25 °C)
- pH 6.5–7.0

2. Minimum salt rejection is 99.4%.

3. Permeate flow rate for each element may vary +25 /-15%.

4. All elements are vacuum sealed in a polyethylene bag containing 1.0% SBS (sodium bisulfite) solution and individually packaged in a cardboard box.

Membrane type:	Thin-Film Composite
Membrane material:	Polyamide (PA)
Element configuration:	Spiral-Wound, FRP Wrapping

Dimensions

Model Name	A	B	C	D / E	Part Number	
					Inter-connector	Brine Seal
RE4040-BE	40.0 inch (1,016 mm)	3.9 inch (99 mm)	0.75 inch (19 mm)	1.05 inch (26.7 mm)	SWA01050	SWA01046



1. Each membrane element supplied with one brine seal, one interconnector (coupler) and four o-rings.
2. All RE4040 elements fit nominal 4.0 inch (101.6 mm) I.D. pressure vessels.

The information provided in this document is solely for informative purposes. It is the user's responsibility to ensure the appropriate usage of this product. Toray Advanced Materials Korea Inc. assumes no obligation, liability or damages incurred for the misuse of the product or for the information provided in this document. This document does not express or imply any warranty as to the merchantability or fitness of the product.

RE4040-BE

High productivity RO element with extended area for brackish water



APPLICATION DATA:

Operating Limits

- Max. Pressure Drop / Element	15 psi (0.1 MPa)
- Max. Pressure Drop / 240" Vessel	60 psi (0.41 MPa)
- Max. Operating Pressure	600 psi (4.14 MPa)
- Max. Feed Flow Rate	18 gpm (4.09 m ³ /hr)
- Min. Concentrate Flow Rate	4 gpm (0.91 m ³ /hr)
- Max. Operating Temperature	113 °F (45 °C)
- Operating pH Range	2.0–11.0
- CIP pH Range	1.0–13.0
- Max. Turbidity	1.0 NTU
- Max. SDI (15 min)	5.0
- Max. Chlorine Concentration	< 0.05 mg/L

Design Guidelines for Various Water Sources

- Wastewater Conventional (SDI < 5)	8–12 gfd
- Wastewater Pretreated by UF/MF (SDI < 3)	10–14 gfd
- Seawater, Open Intake (SDI < 5)	7–10 gfd
- Seawater, Beach Well (SDI < 3)	8–12 gfd
- Surface Water (SDI < 5)	12–16 gfd
- Surface Water (SDI < 3)	13–17 gfd
- Well water (SDI < 3)	13–17 gfd
- RO permeate (SDI < 1)	21–30 gfd

Saturation Limits (Using Antiscalants)[†]

- Langlier Saturation Index (LSI)	<+1.5
- Stiff and Davis Saturation Index (SDSI)	<+0.5
- CaSO ₄	230% saturation
- SrSO ₄	800% saturation
- BaSO ₄	6,000% saturation
- SiO ₂	100% saturation

[†]The above saturation limits are typically accepted by proprietary antiscalant manufacturers. It is the user's responsibility to ensure proper chemical(s) and concentration are dosed ahead of the membrane system to prevent scale formation anywhere within the membrane system. Membrane elements fouled or damaged due to scale formation are not covered by the limited warranty.

GENERAL HANDLING PROCEDURES

- Elements contained in the boxes must be kept dry at room temperature (7–32°C; 40–95°F) and should not be stored in direct sunlight. If the polyethylene bag is damaged, a new preservative solution (sodium bisulfite) must be added and air-tight sealed to prevent drying and biological growth.
- Permeate from the first hour of operation should be discarded to flush out the preservative solution.
- Elements should be immersed in a preservative solution during storage, shipping and system shutdowns to prevent biological growth and freezing. The standard storage solution contains 1% by weight sodium bisulfite or sodium metabisulfite (food grade). For short term storage (i.e. one week or less) 1% by weight sodium metabisulfite solution is adequate for preventing biological growth.
- Keep elements moist at all times after initial wetting.
- Avoid excessive pressure and flow spikes.
- Only use chemicals compatible with the membrane elements and components. Use of such chemicals may void the element limited warranty.
- Permeate pressure must always be equal or less than the feed/concentrate pressure. Damage caused by permeate back pressure voids the element limited warranty.

Toray Advanced Materials Korea Inc.

For more information on our products, company and regional contacts, please visit our website at www.csmfilter.com.

Product Specification Sheet / Model RE4040-BE

Page 2 of 2

Rev.4.0 March 2019

Replacing the Membrane

WARNING – ***Make sure to release the pressure in the vessel prior to opening.***

1. *Unscrew screws that hold metal brackets*
2. *Slide metal bracket out of groove and remove.*
3. *Remove end cap.*
4. *Open the vessel.*
5. *Remove the membrane from the vessel from the feed inlet end.*
6. *Make sure the outside surface of the membrane and the inside surface of the vessel are clean and smooth.*
7. *Lubricate the prepared membrane seals with an approved lubricant suitable for the membranes. (Not silicone)*
8. *Note the directional flow arrow on the membrane matches the flow of the membrane vessel*
9. *Push the membrane with seals into the vessel from the feed inlet end. Make sure that the opening of seals faces the feed flow end.*

WARNING – ***Wrong installation direction of membrane may cause damage to the membrane element.***

10. *Push the membrane until the membrane completely fits into the other end. If there is difficulty in pushing the membrane, check whether the seals of the membrane are installed correctly. Make sure that the membrane is inserted into the vessel from the upstream end.*
11. *Close the vessel.*

WARNING – ***Never pressurise the vessel until the membrane is correctly installed.***

NOTE – *Check for leaks.*

LOW PRESSURE SWITCH

PRODUCT SPECIFICATION

ITEM CODE: SWLP-H06 / SWLP-H20

**DESCRIPTION: ADJUSTABLE PRESSURE SWITCH
0-6KGS / 0-20KGS**

- For use with non-corrosive refrigerant as well as with air and water.
- Allowable fluid temp.: 10 - 120°C
- Double snap-action contact mechanism ensures reliable switching.
- Type SNS for universal application.
- Mounting bracket included.

ELECTRIC CONTACT CAPACITY

MOTOR RATING	POWER	125VAC	250VAC
Non-inductive Ampere	1A	10A	5A
Full load Ampere	0.75A	8.5A	4.5A



SPECIFICATIONS

MODEL	UNIT : kg/cm ²						MAX. WORKING PRESSURE	MAX. ALLOWABLE PRESSURE
	INITIAL SETTING		ADJUSTING RANGE		DIFF.			
	OFF	ON	MIN.	MAX.	MIN.	MAX.		
SWLP-H06	3±0.2	2±0.2	1	6	1	4	15	16
SWLP-H20	15±0.3	12±0.3	5	20	2	5	30	33

MEASUREMENTS

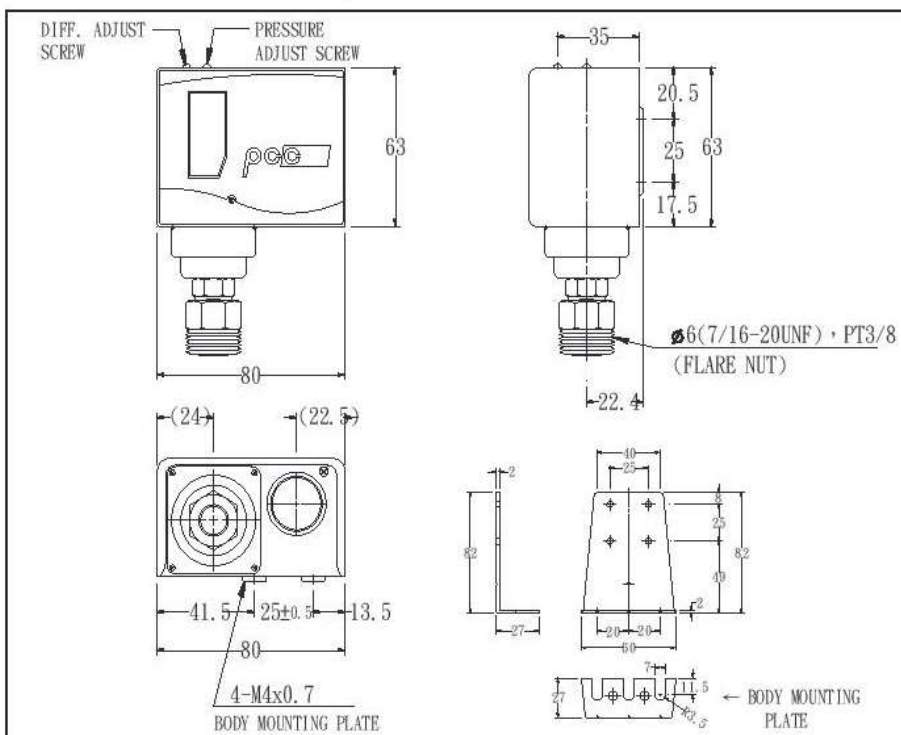

PRESSURE CONNECTION PORT

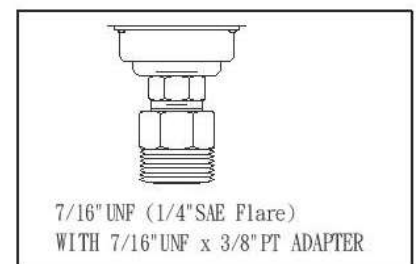

STANDARD ↑

CONTACT FUNCTION

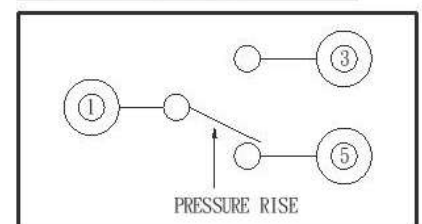

1: COMMON TERMINAL

3: CLOSE ON, PRESSURE DECREASE

5: CLOSE ON, PRESSURE INCREASE

Maintenance Records

INSTALLATION

Permeate conductivity reading: μ s
Inlet conductivity reading: μ s
Concentrate flow:lpm
Recycle flow:lpm
Permeate flow:lpm @ $^{\circ}$ C
Inlet pressurepsi
Outlet pressurepsi

1ST SERVICE

Permeate conductivity reading: μ s
Inlet conductivity reading: μ s
Concentrate flow:lpm
Recycle flow:lpm
Permeate flow:lpm @ $^{\circ}$ C
Inlet pressurepsi
Outlet pressurepsi

2ND SERVICE

Permeate conductivity reading: μ s
Inlet conductivity reading: μ s
Concentrate flow:lpm
Recycle flow:lpm
Permeate flow:lpm @ $^{\circ}$ C
Inlet pressurepsi
Outlet pressurepsi

3RD SERVICE

Permeate conductivity reading: μ s
Inlet conductivity reading: μ s
Concentrate flow:lpm
Recycle flow:lpm
Permeate flow:lpm @ $^{\circ}$ C
Inlet pressurepsi
Outlet pressurepsi