

Connecting the System

Screw elbows into inlet and outlet ports on system.

Connect tubing into elbow (see diagram for Jaco style fittings in general information).

Connect system as shown below

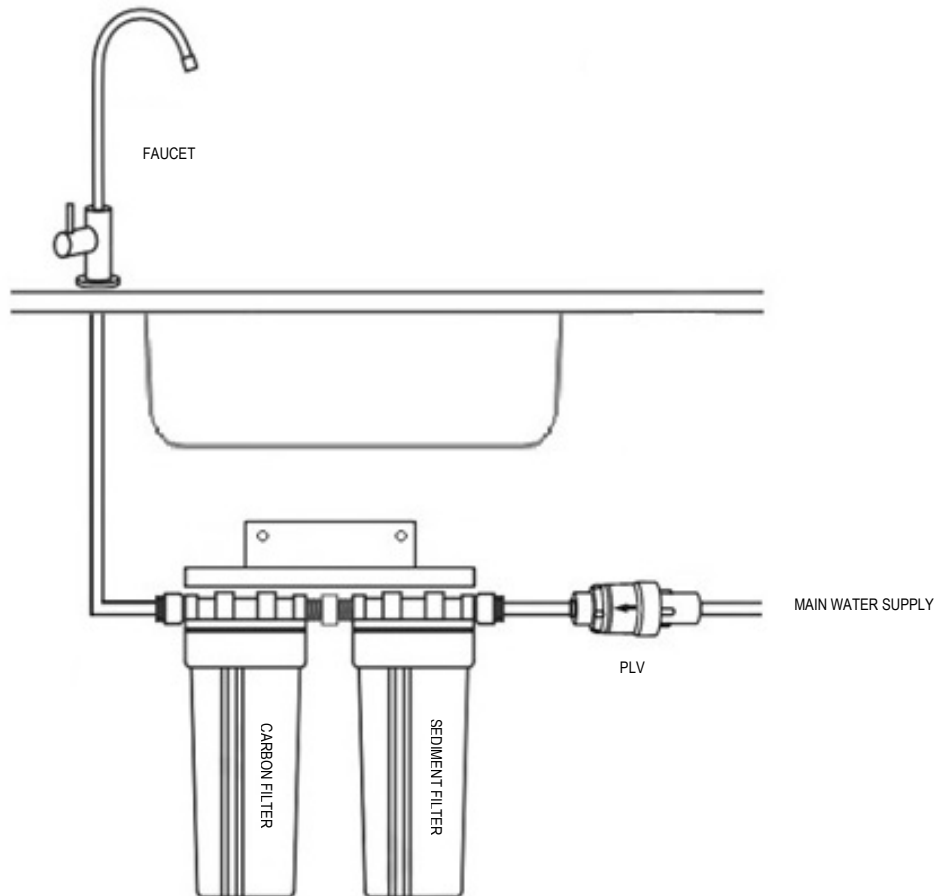

Mounting the System

Mark screw locations at the desired installation point. Use the two holes on the back of the mounting bracket as a guide.

Drill appropriate size holes for wall plugs (if required) or screws.

Screw in screws, leaving the screw head out a little for bracket to sit on.

Mount the system onto the screws

System Start up Procedure

Make sure inlet ball valve is turned 'off' and faucet is 'open' before turning main water supply on.

Unscrew sumps. Remove wrapping from filters. Replace filters into sumps and screw back on. Do not over tighten.

Turn inlet ball valve to the 'on' position and allow system to fill and pressurise. **CHECK FOR LEAKS!**

Allow water to run through for approx. 10-15 minutes. This allows carbon fines to be flushed out. Turn faucet "off". **CHECK FOR LEAKS!**

System is now ready for use.

Filter Change Procedure

* System services and filter changes should be done by a licensed plumber *

** Only use cartridges that are suitable for this system **

Turn ball valve to the 'off' position and open faucet to release the pressure.

Slip opening handle over the sump and unscrew it. (System may need to be laid down to get better leverage)

Discard used filters and rinse sumps out with warm water. * Using soap to clean sumps is not recommended *

Insert new filters – Sediment filter on water inlet side and carbon block on outlet side.

Ensure sumps have their o-rings freshly lubricated and seated properly before screwing back on.

Turn inlet ball valve to 'on' position and flush the system for 10-20 minutes to expel any carbon fines. Turn faucet 'off'. **CHECK FOR LEAKS!**

Maintenance Schedule

During a service, PLV should be tested, o-rings should be lubricated with silicone grease and system should be checked for general wear and tear.

We recommend turning system off at inlet ball valve if it is to be unused for more than 2 days.

If unused for more than 2 days, you will need to flush 5-10 litres of water through system before use.

SEDIMENT & CARBON FILTERS Replace every 12 months

HOUSINGS Replace every 5 years

PLV 2 year warranty
Replace every 5 years

FAUCET Replace every 5-10 years

FITTINGS & TUBING Replace every 5 years

System Limitations

	MAX	MIN
Pressure	100 psi	30 psi
Flow Rate	4 lpm	0.5 lpm
Temperature	38°C	4°C

Troubleshooting

NO WATER FROM FAUCET

- No water supply.
 - Check water supply is turned on.
- Lines may be kinked.
 - Check lines and make sure straight and unhindered.
- Incorrect installation
 - Check and verify all line connections

SLOW FLOW FROM FAUCET

- Low water pressure.
 - Check inlet water pressure and increase or add pump to system.
- Water inlet is blocked or not fully open.
 - Check feed water valve is fully open
 - Check PL/DCV is not blocked
- Filters clogged.
 - In high volume or bad water quality applications these may need to be replaced more regularly.

AIR BUBBLES (CLOUDY WATER) IN GLASS WHEN FILLING

- This is normal with new systems or after a filter change and can sometimes take up to 3 weeks to dissipate.
 - To check if air bubbles, fill glass and let sit. The air bubbles will rise to the top leaving a clear glass of water.

HOUSINGS LEAKING

- Check for cracks.
- Check o-ring is properly in place.
 - Replace o-ring if damaged
 - Clean and lubricate o-ring with silicone grease if dirty.

Warranty

CRYSTAL CLEAR PURIFICATION SYSTEMS TERMS AND CONDITIONS

TERMS AND CONDITIONS

Any contract of sale, order, or quotation made or accepted by or on behalf of Crystal Clear Purification Systems Pty Ltd ("Crystal Clear") is subject to these terms and conditions of sale.

WARRANTY

Crystal Clear warrants each new product to be free from defects in material and workmanship for a period of 1 year from the date of retail sale established by the date of the original invoice issued by Crystal Clear.

The Product must be forwarded at the Buyer's own risk and expense to Crystal Clear, together with proof of purchase. Any damage caused during or as a result of transit will not be the responsibility of Crystal Clear.

Crystal Clear's exclusive obligation under this Warranty is, at Crystal Clear's own option, to either repair or replace the Product, once Crystal Clear has deemed that the Product is defective.

Crystal Clear may, at its own discretion, refund to the Buyer the purchase price paid for the defective goods.

Crystal Clear reserves the right in instalment sales to grant credit for the value of any Product found to be defective under this Warranty.

Crystal Clear will not cover any labour charge incurred by the Buyer for the replacement or repair of any Product.

The Buyer is responsible for freight and local labour charges for Products the subject of this Warranty.

This Warranty applies only to the original retail purchaser of the Product.

This Warranty does not cover any Product that is relocated from the site of its original installation.

All replaced or exchanged parts taken out under this warranty become the property of Crystal Clear.

LIMITED WARRANTY

Crystal Clear's liability for any breach of this Warranty shall be limited solely to replacement or repair at the sole option of Crystal Clear, of any part or parts found to be defective during the Warranty Period.

In no event will liability extend beyond the purchase price of the product.

This Warranty is subject to the Product being properly installed and maintained and being used for its intended purpose.

The Warranty will be void if the goods have found to be tampered with.

This Warranty does not cover the normal wear and tear of the Product, or damage caused by misuse, abuse or vandalism.

This Warranty does not extend to a Product that has been modified in any way unless with Crystal Clear's express consent.

The Warranty does not cover any malfunction or failure resulting from neglect or use of unauthorised parts and accessories, improper water pressure etc.

The Warranty does not extend to damage caused by rain, fire, earthquake or other natural causes or acts of nature.

It is expressly agreed that this shall be the sole and exclusive remedy of the buyer stated herein, and under no circumstances shall Crystal Clear be liable for any costs, loss, expense, damages, special damages, incidental damages or consequential damages arising directly or indirectly from the design, manufacture, sale, or use or repair of the product whether based upon warranty, contract, tort or strict liability.

The Warranty limits Crystal Clear's liability and is in lieu of all other warranties and liabilities expressed or implied.

All implied warranties of merchantability and fitness for a particular purpose are hereby disclaimed by Crystal Clear and excluded from the Warranty.

WARRANTY PROCEDURE

Goods damaged during transit must be reported within five (5) working days of delivery.

Insured goods damaged during transit must be reported within twenty-four (24) hours of delivery.

A copy of the original invoice must be presented for any Warranty claim as proof of purchase.

The faulty item must be returned to Crystal Clear if such a request is made.

This limited Warranty is void if the Product under Warranty is presented without the said original invoice.

Crystal Clear may request that a Statement accompany the original invoice, signed by the Buyer, setting out the following terms:

1. The name and address of the Buyer.
2. The date and by whom the Product was purchased.
3. The date and by whom the Product was installed.
4. The location where the Product was installed.
5. The date and time the Product first appeared to malfunction.
6. The nature of the problem with the Product.
7. The date and time of any and all loss event/s.
8. The date and time Crystal Clear was first notified of the Product malfunction.

A failure by the Buyer to submit the said Statement within 28 days, after such request is made by Crystal Clear, will automatically void the Warranty.

A failure to answer truthfully or to answer in a way that is misleading, entitles Crystal Clear to void the Warranty and to notify the police in the event of suspected fraudulent conduct.

RISK

The risk in the Product will pass to the Buyer immediately upon the Product leaving Crystal Clear's premises for delivery to the place designated by the Buyer.

RETENTION OF TITLE

Crystal Clear will retain title to (but not risk in) a Product delivered to the Buyer until Crystal Clear has received payment in full for the Product and all other sums owing to it by the Buyer.

Until such payment, the Buyer holds the Product as bailee for Crystal Clear and may not sell or otherwise dispose of the Product unless authorised by Crystal Clear. If the Product is sold, the proceeds of sale will be placed in a separate trust account pending payment to Crystal Clear. The Buyer will store the goods in such a way as to enable them to be separately identified and will keep them insured at its own expense with Crystal Clear's interest noted on any such insurance cover.

If the Buyer fails to make any payment when due or becomes bankrupt or becomes insolvent, or has a judgement entered against it in any Court or enters into any scheme of arrangement, composition, or assignment or is in receivership or voluntary administration or liquidation, the Buyer grants Crystal Clear licence to enter any of the Buyer's premises where the Product is stored, and without notice, to re-take possession of and remove, at the Buyer's cost and expense, the Product in respect of which title has not passed to the Buyer.

THIS WARRANTY IS VOID IF

All filter housings are not installed with an Australian Standards approved pressure limiting and check valve.

The system is not turned off when residents are away for over 24 hours

The system is not serviced every 12 months. I.e. Replacement of filters, PLV check & assessment of general condition of system.

Product damage results from water hammer, freezing, neglect or is not installed by a licensed plumber in accordance with the installation plan.

A system connected to a chiller that does not have an expansion chamber, is not installed with a Pressure Relief Valve.

The water temperature exceeds 40° Celsius

The pressure exceeds 700kpa

SEVERANCE

If any of these terms or conditions or becomes for any reason wholly or partly invalid, that term or condition shall to the extent of the invalidity be severed without prejudice to the to the continuing force and validity of the remaining terms and conditions

JURISDICTION

Crystal Clear and the buyer agree that this agreement and its provisions shall be construed in accordance with the laws of the State of South Australia and be resolved by a South Australian Court.

Service Record

Installation Date: ___/___/___

Next Service Due: ___/___/___

1st Service: ___/___/___

Serviced By: _____

PLV Checked: Good Replace next FC

Housing condition: Good Replace next FC

Next Service Due: ___/___/___

SERVICE NOTES:

2nd Service: ___/___/___

Serviced By: _____

PLV Checked: Good Replace next FC

Housing condition: Good Replace next FC

Next Service Due: ___/___/___

SERVICE NOTES:

3rd Service: ___/___/___

Serviced By: _____

PLV Checked: Good Replace next FC

Housing condition: Good Replace next FC

Next Service Due: ___/___/___

SERVICE NOTES:

4th Service: ___/___/___

Serviced By: _____

PLV Checked: Good Replace next FC

Housing condition: Good Replace next FC

Next Service Due: ___/___/___

SERVICE NOTES:

5th Service: ___/___/___

Serviced By: _____

PLV Checked: Good Replace next FC

Housing condition: Good Replace next FC

Next Service Due: ___/___/___

SERVICE NOTES: