

CF28 CLUSTER HOUSING

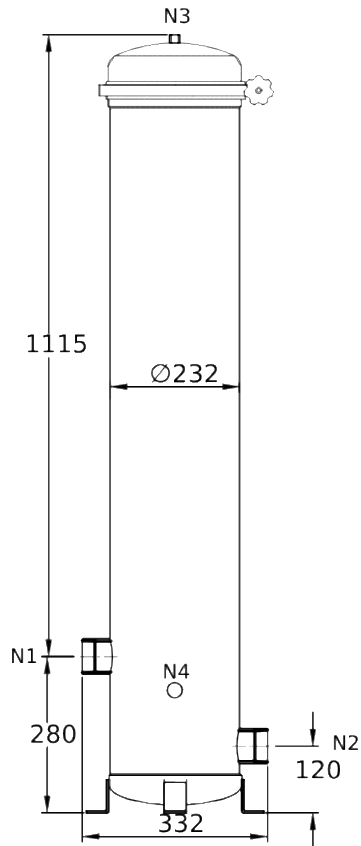

- N1 2" F NPT Inlet
- N2 2" F NPT Outlet
- N3 1/4" F NPT Vent
- N4 3/4" M NPT Drain

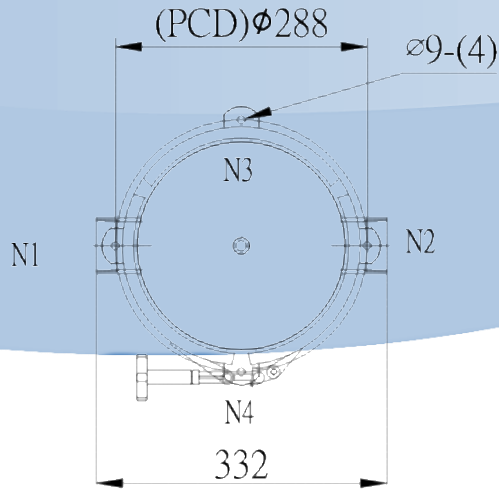

Max working pressure 30 – 150 psi
 Working temperature 1 - 50°C
 Surface 316 S/Steel
 Material Electrolyze

- 1 Clamp 304 or 316 S/Steel
- 2 Vent 304 or 316 S/Steel
- 3 Top Cover 304 or 316 S/Steel
- 4 O-Ring EPDM
- 5 Shell Flange 304 or 316 S/Steel
- 6 Shell 304 or 316 S/Steel
- 7 Inlet 304 or 316 S/Steel
- 8 Outlet 304 or 316 S/Steel
- 9 Drain 304 or 316 S/Steel
- 10 Bottom Cover 304 or 316 S/Steel
- 11 Support Leg 304 or 316 S/Steel
- 12 Nut 304 or 316 S/Steel
- 13 Press Plate 304 or 316 S/Steel
- 14 Springs 304 or 316 S/Steel
- 15 Cartridge Posts 304 or 316 S/Steel
- 16 Center Post 304 or 316 S/Steel
- 17 Nut 304 or 316 S/Steel
- 18 Pedestal 304 or 316 S/Steel
- 19 Cartridge Support Plate 304 or 316 S/Steel

