

# CF14 CLUSTER HOUSING

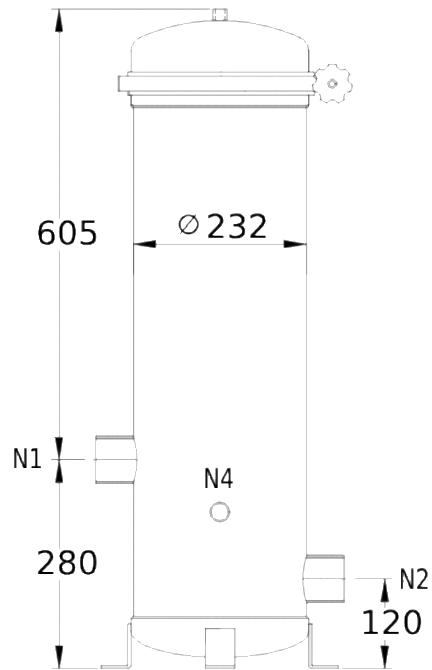

- N1 1 ½" F NPT Inlet
- N2 1 ½" F NPT Outlet
- N3 1/4" F NPT Vent
- N4 3/4" MNPT Drain

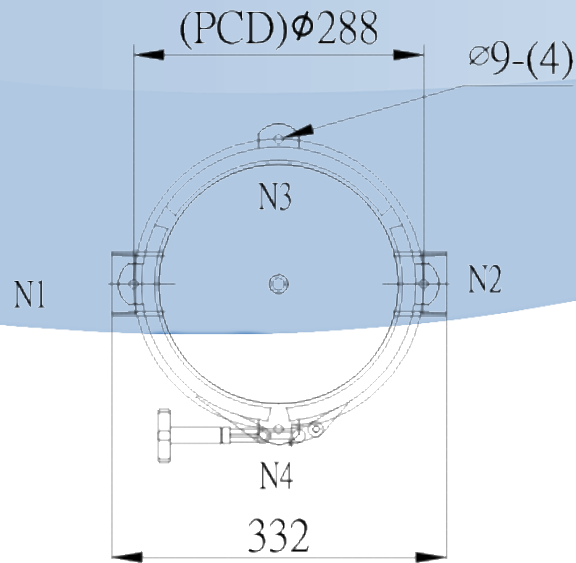
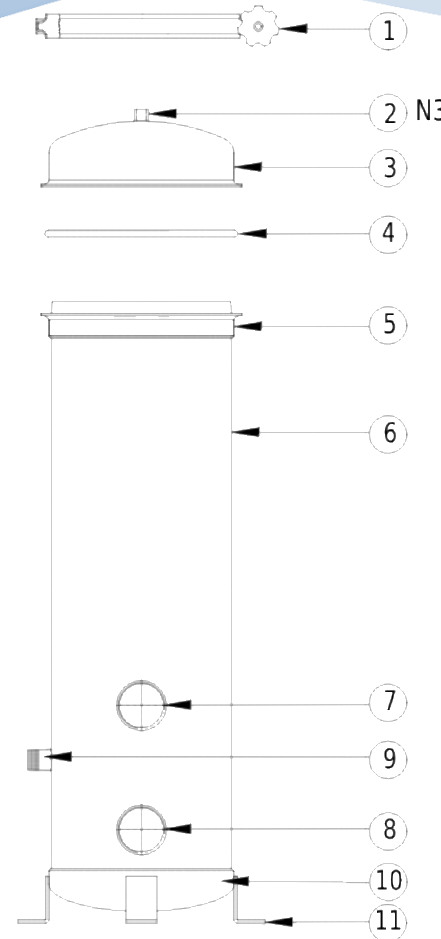

Max working pressure 30 – 150 psi  
 Working temperature 1 - 50°C  
 Surface 316 S/Steel  
 Material Electrolyze

- 1 Clamp 316 S/Steel
- 2 Vent 316 S/Steel
- 3 Top Cover 316 S/Steel
- 4 O-Ring EPDM
- 5 Shell Flange 316 S/Steel
- 6 Shell 316 S/Steel
- 7 Inlet 316 S/Steel
- 8 Outlet 316 S/Steel
- 9 Drain 316 S/Steel
- 10 Bottom Cover 316 S/Steel
- 11 Support Leg 316 S/Steel
- 12 Nut 316 S/Steel
- 13 Press Plate 316 S/Steel
- 14 Springs 316 S/Steel
- 15 Cartridge Posts 316 S/Steel
- 16 Center Post 316 S/Steel
- 17 Nut 316 S/Steel
- 18 Pedestal 316 S/Steel
- 19 Cartridge Support Plate 316 S/Steel

